

**Kurzweil 3000**

**Version 10**

*Training Guide*

**Developed by Myra Lerch & Kate Houchin**

**Disabled Student Programs & Services**

**Butte College**

**March 2008**

## Kurzweil 3000, v. 10 Contents & Training Sequence

Page

### Scanning & Reading

Background & Scanning.....	1
Reading.....	3
Foreign Languages (optional).....	7
Adjusting Colors & Caret .....	9
References: Definition, Synonym, Syllables, & Spell.....	11
Basic Keyboard Commands .....	14

### Study Skills & Writing

Study Skills: Highlighting.....	15
Study Skills: Footnotes (optional) .....	21
Printing.....	23
Writing: Basics & Spell Check.....	24
Writing: Word Prediction .....	26
Fill in the Blanks (optional) .....	31
Internet: Reading the Web .....	33

### Saving Scanned Materials

Saving Options .....	35
Saving: Kurzweil File.....	36
Saving: MP3 File.....	44
Individual Profile.....	51

# Background & Scanning

DSP&S  
Butte College

## Background & Scanning Kurzweil 3000

### BACKGROUND:

➤ Allows user to scan material & see it on computer screen as it is read aloud

- Provides auditory access to print for students with reading difficulty
- Helpful for different learning styles:

⇒ Scanning & reading:

- Visual verbal
- Auditory

⇒ Highlighting:

- Visual nonverbal
- Kinesthetic

➤ Helps with retention; provides information through two channels

In general, we retain approximately:

- 20% of material through auditory channel alone
- 30% of material through visual channel alone
- 50% of material through both auditory & visual channels combined

➤ Provides study skills features

➤ Reads Microsoft Word documents & Internet aloud

- Ability to read web pages depends on how they were created

### A FEW TIPS . . .

- If you highlight your text, use yellow, green, or blue markers.
  - Orange or pink highlighting will mask scanned text.
- If you underline, do not let lines cross over text.
- Students often prefer using their own headphones in mainstream settings. Purchase headphones with volume control on the cord.

## Background & Scanning

### TO LAUNCH PROGRAM:

1. Turn on equipment:
  - Turn on scanner, then computer
2. On the desktop, double-click **Kurzweil 3000**

### TO SCAN:

1. Place materials in scanner
  - Place materials face down, lining up edge of page with edge of glass
2. Close lid: If necessary, put slight pressure on lid while scanning
3. Scan:
  - Click **Scan** on toolbar, <OR>
  - *Keyboard: F9*

OPTION: For smaller books, you can scan two pages at a time (turning book sideways):

- ✓ **Scan** menu > **Two Page Mode**
- ✓ Kurzweil will still display the pages individually

### TO RESCAN:

If original scan is unacceptable: **Scan** menu > **Rescan Page**

### TO SCAN MULTIPLE PAGES:

1. Put additional page(s) in scanner & click **Scan**
2. Once finished scanning additional pages:
  - Click **Down Arrow** next to **Page** edit box to view previous page, <OR>
  - Click **Up Arrow** to view next page, <OR>
  - Click **1** for first page



DSP&S  
Butte College

## Reading Kurzweil 3000

### TO READ:

To start reading - 2 methods:

1. Click **Read / Pause** button on toolbar, <OR>
2. *Keyboard: F3*



### READING OPTIONS:

#### Read Mode:

1. Continuous: Starts at beginning and reads to final page (*Default*)
2. Self-paced: Reads one unit before stopping – *Example: paragraph*
3. Word by word: Reads one word, then stops

⇒ *Preferred setting:* \_\_\_\_\_

#### Reading Unit:

1. Word
2. Phrase
3. Line
4. Sentence (*Default*)
5. Paragraph
6. Heading (Consider this to preview a chapter by hearing headings)
7. Highlight (Reads only the text you have highlighted)

⇒ *Preferred setting:* \_\_\_\_\_

#### WPM:

1. Sets reading speed; click up/down arrow to adjust
2. Range: 35 - 600 WPM

⇒ *Preferred setting:* \_\_\_\_\_ WPM

#### Zoom:

1. Sets magnification level; click up/down arrow to adjust
2. Range: 25 - 2000%

Suggestion: Optimize display by sizing text to fill screen width

1. **View** menu > **Fit To** > **Text Width** (*Default*) <OR> *Keyboard: F5*

## TO CHANGE SPEAKER:

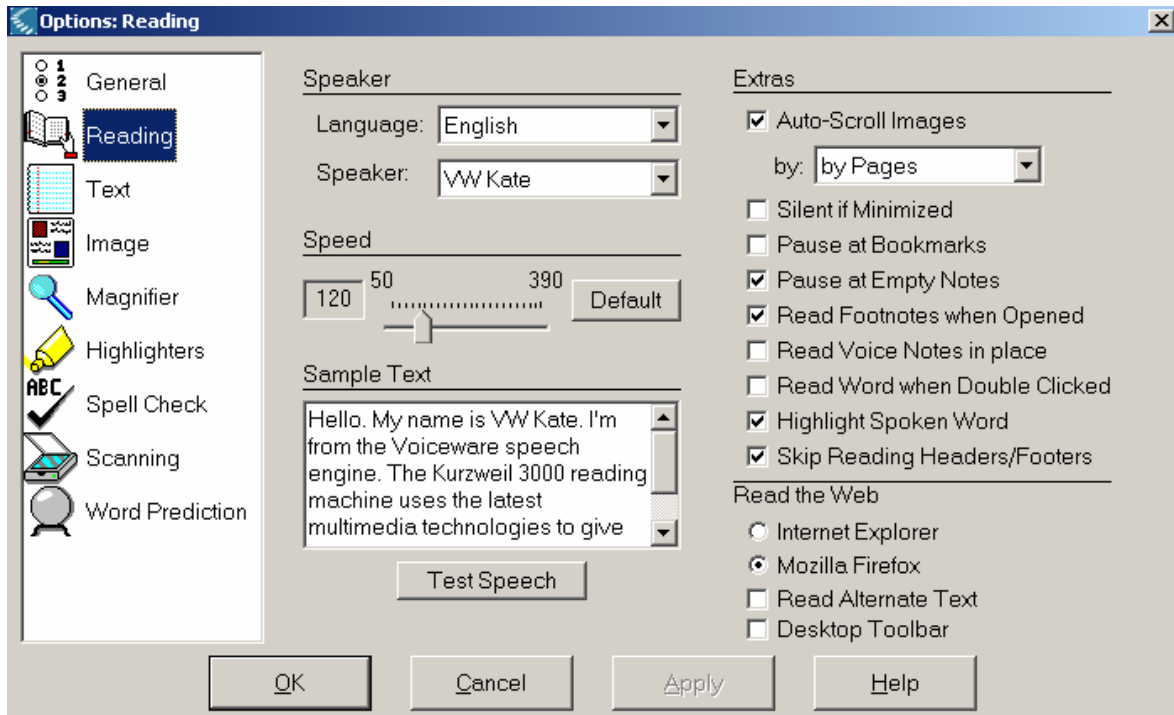

1. **Tools** menu > **Options** <OR> *Keyboard: <Ctrl> + F1*
2. Click **Reading** in Side Menu
3. Select Speaker - Speaker options may include the following:

- Default Male & Female voices (several listed)
- Carol                      Justin                      Nicky
- Crystal 16\*              LH Michael              Peter
- Mike 16\*                      LH MichelleReed
- Gramps                      Microsoft Mary              Sandy
- Grandma                      Microsoft Mike              Shelley
- Grandpa                      Microsoft Sam              VW Kate\*\*
- Jane                              Nanny                              VW Paul\*\*

**\*AT&T & \*\*NeoSpeech voices: many listeners prefer them**

4. Click **Test Speech** to hear sample, then click **OK** when finished

⇒ *Preferred setting #1:* \_\_\_\_\_

⇒ *Preferred setting #2:* \_\_\_\_\_

### TO CHANGE PRONUNCIATION:

This option lets you change the way Kurzweil pronounces a word

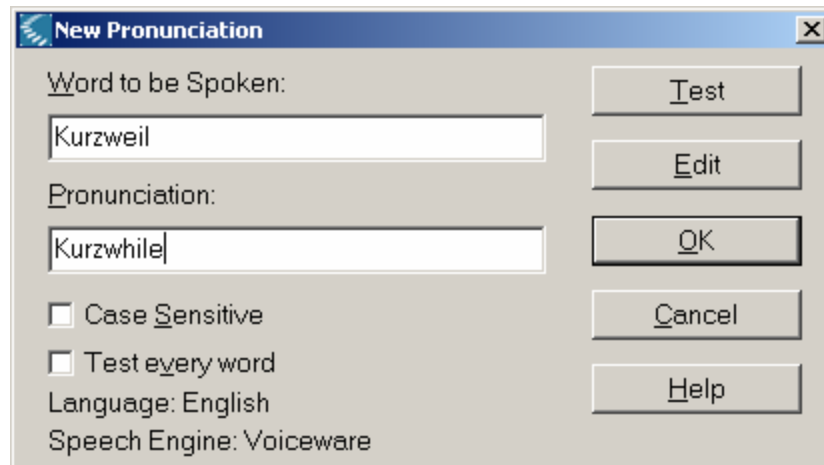

1. Select the word you want to change
2. **Tools** menu > **Pronunciations**
3. The selected word appears in **Word to be Spoken** box
4. In **Pronunciation** box, type the way you think word should be pronounced
5. Checkmark **Case Sensitive** if you want the change to apply only to word when it is capitalized or lower case
6. Click **Test** to hear the original and new pronunciation:  
“(Original word)” will be pronounced “(New version)”
7. If pronunciation is ok, click **OK**
8. If pronunciation is not ok:
  - o Type another version in **Pronunciation** box
  - o Then repeat Steps 5, 6, and 7

### TO MAGNIFY SPOKEN WORD:

This option puts a window on screen that magnifies each word individually (or several words) as it is spoken.

- More effective at slower reading speeds

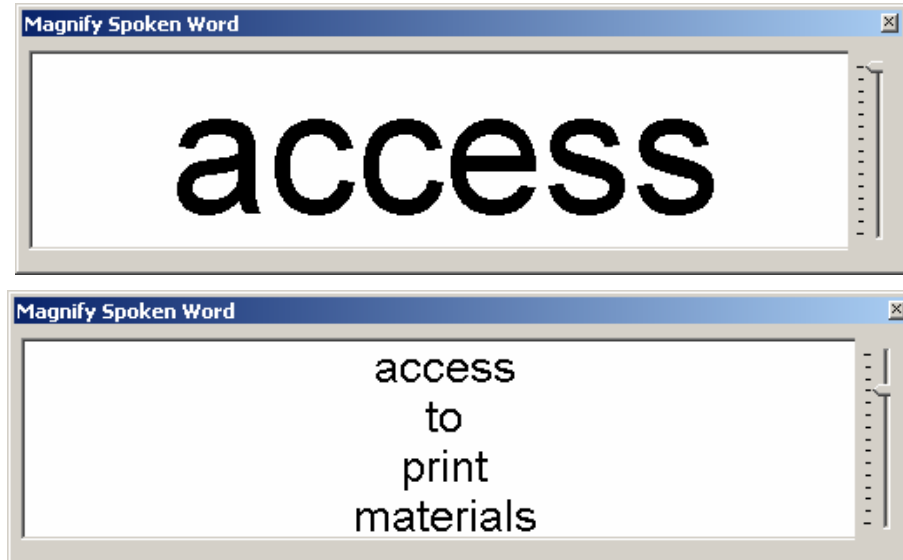

1. **View menu > Magnify Spoken Word**
2. Adjusting the **Magnify Spoken Word** window:
  - Window can be adjusted to display several words
    - Use slider bar on right
    - Range: 1-15 words (see examples above)
  - Window can be resized by clicking & dragging its edge
  - Window can be moved by dragging its title bar

⇒ *Preferred setting: Magnify Spoken Word On / Off (Circle one)*
3. Color options:
  - **Tools** menu > **Options**
  - **Magnifier** in Side Menu
  - Adjust text, background, font & click **OK**

⇒ *Preferred settings*:

**Text:** \_\_\_\_\_

**Background:** \_\_\_\_\_

**Font:** \_\_\_\_\_

## Foreign Languages Kurzweil 3000

### ➤ OVERALL SETUP – 3 MAIN CHANGES:

1. **Set up scanner**
2. **Choose reading language**
3. **Choose speaker**

### ➤ TO SET UP SCANNER:

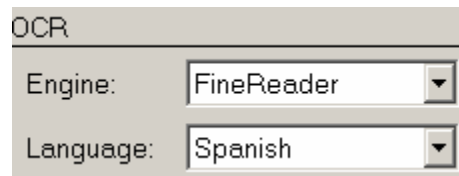

1. **Tools** menu > **Options** <OR> *Keyboard: <Ctrl> + F1*
2. Click **Scanning** in Side Menu
3. Click Language menu & select the scanning language you want
4. Click **Apply**

### ➤ TO CHOOSE READING LANGUAGE:

1. Click **Reading** in Side Menu
2. Click **Language** drop-down menu & select the language you want

#### Options:

- English (*Default*)
- Spanish
- French
- German
- Italian
- Portuguese
- Finnish

## Foreign Languages

### ➤ TO CHOOSE SPEAKER:

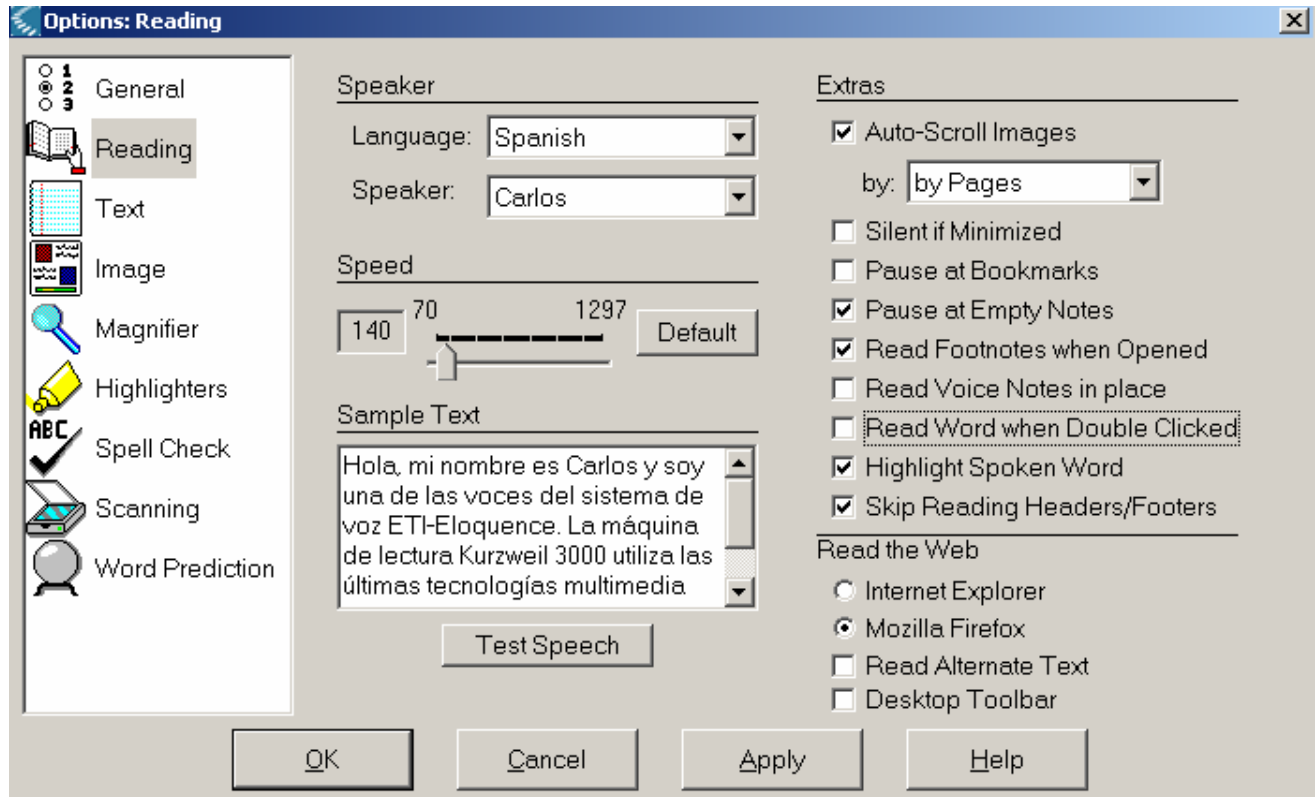

1. Choose Speaker:
  - The specific list of speakers will depend on the language you have selected
  - *Example:* For Spanish, speakers include Carlos, Pilar, Abuelo, Abuela, and others
2. Click **Test Speech** to hear sample (spoken in that language)
3. Click **OK** when finished

⇒ *Preferred setting:* \_\_\_\_\_

DSP&S  
Butte College

## Adjusting Colors and Caret Kurzweil 3000

TO ADJUST COLORS:

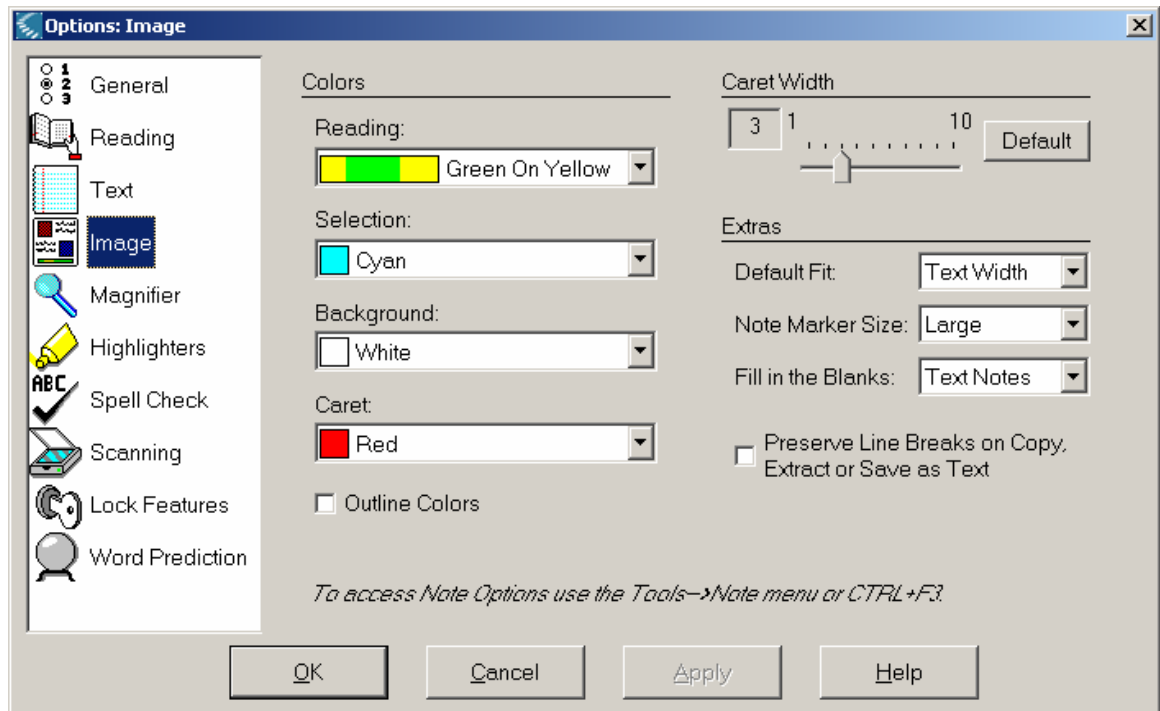

1. **Tools** menu > **Options** <OR> *Keyboard: <Ctrl> + F1*
2. Click **Image** in Side Menu
3. Reading Color:

In **Colors** section, select Reading option:

- Green on Yellow (Default)
- Green on Cyan
- Blue on Magenta
- Red on Magenta

⇒ *Preferred setting:* \_\_\_\_\_

## Colors & Caret

4. Selection Color:
  - Affects color of word you select (*Example*: for definition)
  - Click **Selection** drop-down menu and select a color from list

⇒ *Preferred setting*: \_\_\_\_\_
  
5. Background Color: Changes color of background for scanned text
  - White (*Default*)
  - Rose
  - Peach
  - Sky
  - Gray
  - Slate
  - Granite

⇒ *Preferred setting*: \_\_\_\_\_
  
6. Caret Color: (Caret = cursor)  
Click **Caret** drop-down menu and select a color from list  

⇒ *Preferred setting*: \_\_\_\_\_
  
7. Caret Width: (Caret = cursor)  
Click in **Caret Width** area, then click & drag **Slider** to desired width
  - Range: 1 - 10 (*Default* = 3)
  - Recommended width: 5 – 6 for greater visibility
  - *Keyboard*: Use Left or Right arrow keys to adjust value

⇒ *Preferred setting*: \_\_\_\_\_
  
8. Click **Apply** (or click **OK** if finished)

DSP&S  
Butte College

### References: Definition, Synonym, Syllables, & Spell Kurzweil 3000

- You may want to set Read Mode to Continuous (if you use Self-paced)
- You can enlarge the text in these windows through the Zoom feature
  - Click up/down arrows to adjust

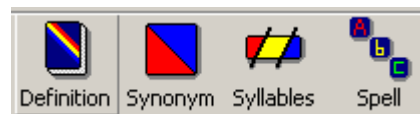

#### DICTIONARY CHOICES:

- **Default: American Heritage - Fourth Edition**
- Kurzweil 3000 offers access to 12 dictionaries, some of which translate between languages (*Example: English → German*).
- To change dictionary:
  - **Reference** menu > **Select Dictionary**

#### DEFINITION:

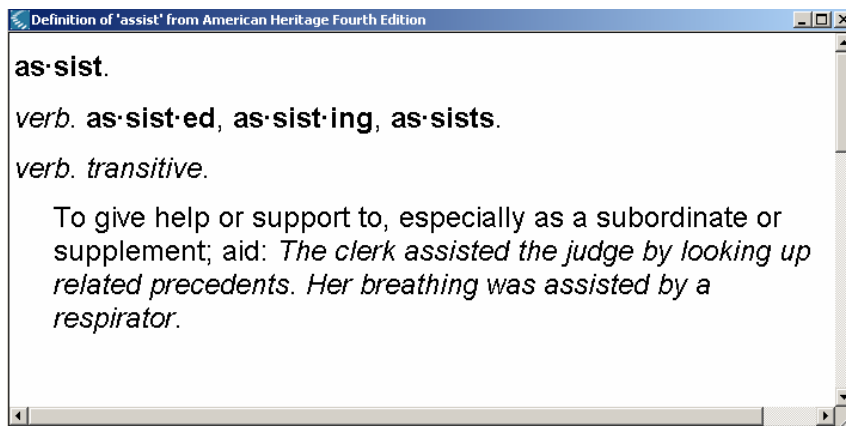

1. Click the word you want (to position caret in front of it)
2. Click **Definition** on toolbar <OR> *Keyboard: <Ctrl> + D*
3. Click **Read** to hear definition
4. Click **Close button (X)** when finished
5. Option: Click a word in definition & get a definition of that word

### SYNONYM:

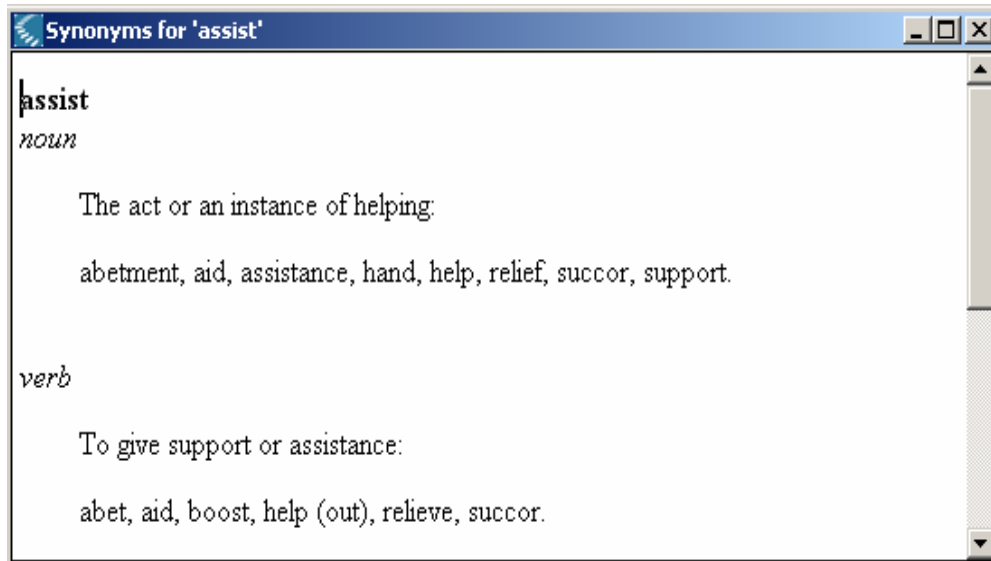

1. Click the word you want (not all words will have synonyms)
2. Click **Synonym** on toolbar <OR> *Keyboard: <Ctrl> + Q*
3. Click **Read** to hear synonyms
4. Click **Close button (X)** when finished

### SYLLABLES:

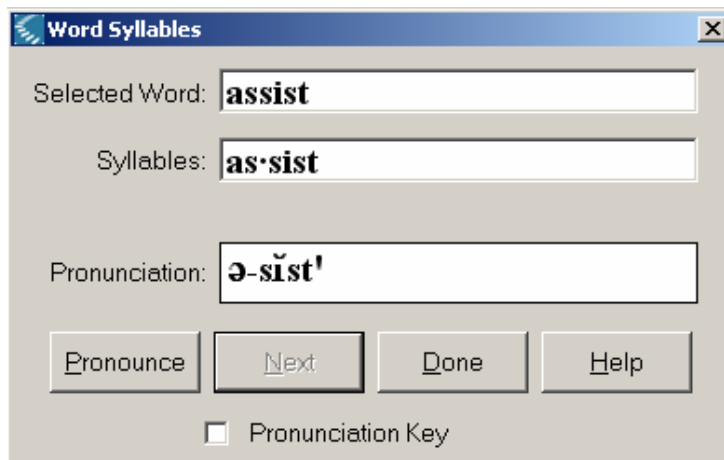

1. Click the word you want
2. Click **Syllables** on toolbar <OR> *Keyboard: <Ctrl> + Y*
3. Kurzweil will read word by syllable
4. Click **Pronounce** to hear word again
5. Click **Done** when finished

### SPELL:

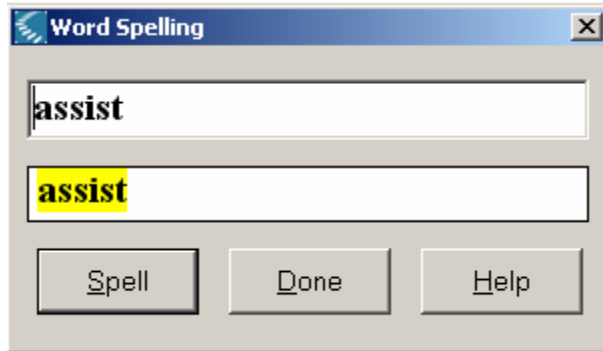

1. Click the word you want
2. Click **Spell** on toolbar, <OR> *Keyboard: <Ctrl> + L*
3. Kurzweil will:
  - Say the word,
  - Spell it aloud while displaying each letter as it is spoken,
  - Then say the word again
4. Click **Spell** to hear word spelled again
5. Click **Done** when finished

### TO LOOK UP YOUR OWN WORD:

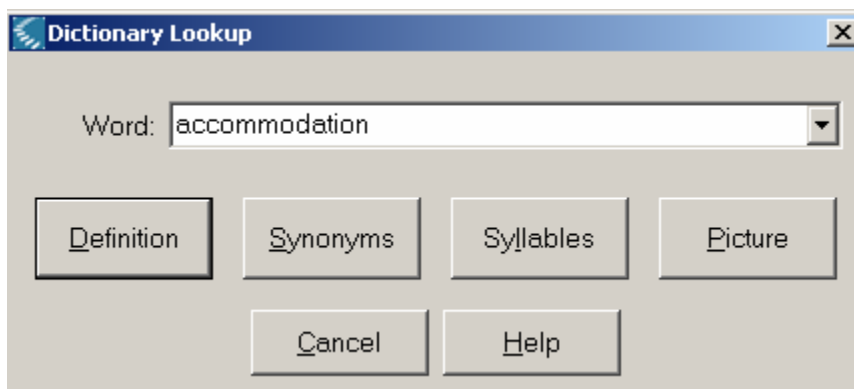

1. **Reference** menu > **Look Up Word I Type**
2. Type word & click **Definition, Synonyms, or Syllables (or Picture)**
3. Click **Read**
4. Click lower **Close button (X)** when finished

# Keyboard Commands

DSP&S  
Butte College

## Basic Keyboard Commands Kurzweil 3000

- F1** = Help
- F2** = Back to previous reading unit (*Example:* previous sentence)
- F3** = Start / Pause Reading
- F4** = Forward to next reading unit (*Example:* next sentence)
- F5** = Fit view to text width
- F6** = Fit view to text height
- F7** = Zoom in by 10% (increases size)
- F8** = Zoom out by 10% (decreases size)
- F9** = Start new scan
- F11** = Increase reading speed
- F12** = Decrease reading speed
- <Ctrl> + F1** = Options dialog box

*Add your own keyboard shortcuts:*

\_\_\_\_\_ = \_\_\_\_\_

\_\_\_\_\_ = \_\_\_\_\_

\_\_\_\_\_ = \_\_\_\_\_

## Study Skills: Highlighting Kurzweil 3000

### BACKGROUND:

- Lets you highlight text & distill out most important material
  - You can then print highlighted material as a study guide
- Four highlight colors available
- Use with Study Skills toolbar displayed on screen



### TO DISPLAY STUDY SKILLS TOOLBAR:

1. Click **green bar** on left end of toolbar

<OR>

1. Right-click any toolbar
2. Highlight **Study Skills** in pop-up menu
3. Click **Large** in submenu to put large-icon Study Skills toolbar on screen

**NOTE:** BEFORE highlighting, if you plan to indent highlighted text to show levels of importance:

- decide which colors you plan to use for which purpose, and
- change indent values (see example, page 16)

## Highlighting

### EXAMPLE: ORIGINAL TEXT & HIGHLIGHTED TEXT WITH INDENT

#### Original text:<sup>1</sup>

Central to spatial intelligence are the capacities to perceive the visual world accurately, to perform transformations and modifications upon one's initial perceptions, and to be able to re-create aspects of one's visual experience. One can be asked to *produce forms or simply manipulate those that have been provided*. Even as musical intelligence consists of rhythmic and pitch abilities which are sometimes **DISSOCIATED** from one another, and as linguistic intelligence consists of syntactic and **PRAGMATIC** capacities which may also come uncoupled, so, too, *spatial intelligence emerges as an amalgam of abilities*.

#### EXAMPLE: Setting up indent (see above paragraph)

Content	Color	Indent amount
Main idea	Yellow	No indent
Supporting details	Green	1.0"
Vocabulary	Cyan	2.0"

#### EXAMPLE: Highlighted text with indent

**(Main idea – identified in bold above)**

Central to spatial intelligence are the capacities to perceive the visual world accurately, to perform transformations and modifications upon one's initial perceptions, and to be able to re-create aspects of one's visual experience.

**(Supporting details – identified in italics above)**

Produce forms or simply manipulate those that have been provided  
Spatial intelligence emerges as an amalgam of abilities

**(Vocabulary – identified in ALL CAPS above)**

dissociated  
pragmatic

---

<sup>1</sup> H. Gardner, *Frames of Mind*. New York: BasicBooks, 1983.

## Highlighting

### TO INDENT HIGHLIGHTED TEXT: (See example, p. 16)

- This feature indents highlighted text according to color
- Helps organize highlighted text in order of importance

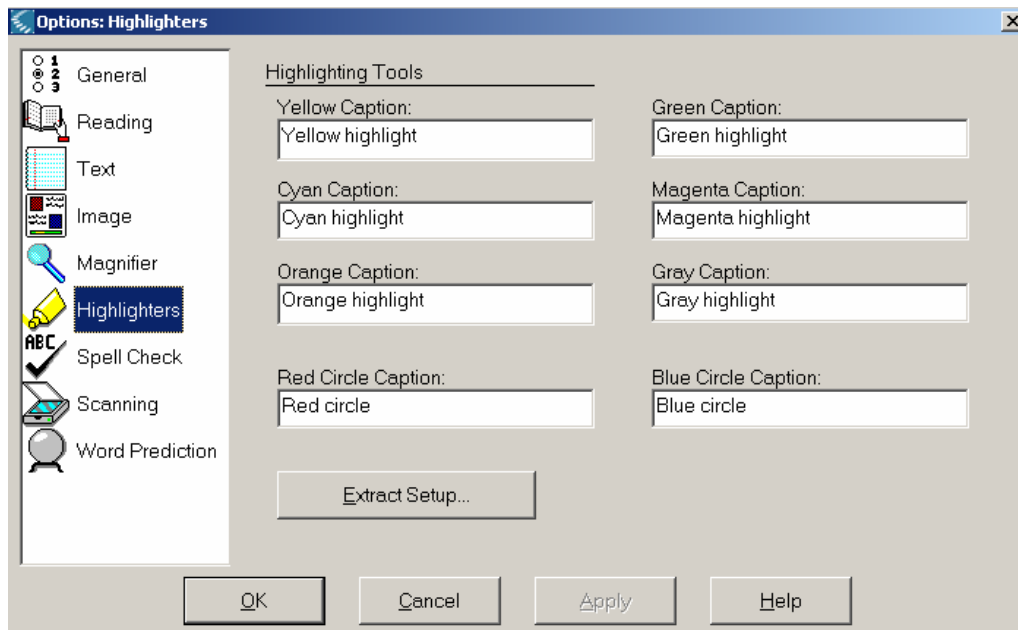

1. **Tools** menu > **Options** <OR> *Keyboard: <Ctrl> + F1*
2. Click **Highlighters** in Side Menu > **Extract Setup**
3. For each highlight color, click **Indent** text box, delete current value, & type the indent value you want for that color
4. Click **OK**, then click **OK** in Highlighters dialog box

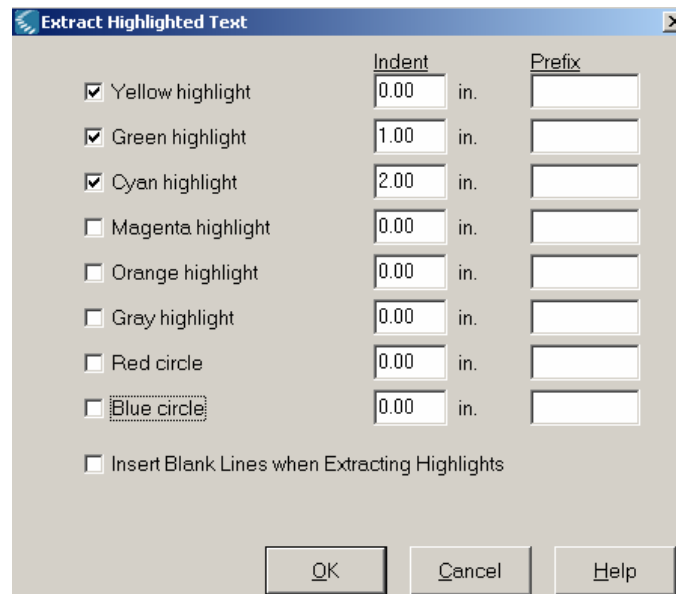

## Highlighting

### TO HIGHLIGHT TEXT:



1. Click a **Highlighter** button on Study Skills toolbar:
  - Yellow, Green, Cyan, or Magenta
  - Mouse pointer becomes a highlighter pen
2. Click and drag pen to highlight desired text
3. To change colors, click another highlighter button
4. To stop, click **Highlighter** button again

### TO ERASE HIGHLIGHTING:

1. Click **Erase** on Study Skills toolbar
2. Click and drag pen over highlighted text to erase highlighting

### TO READ HIGHLIGHTED TEXT:

1. Click **Reading Unit** box on Reading toolbar (*Example: Sentence, Paragraph*)
2. Click **Highlight**
3. Click to place caret at beginning of highlighted text
4. Click **Read**

### TO PRINT HIGHLIGHTED TEXT:

1. Click **Print** on Toolbar
2. Click **Highlighted Text** (otherwise, will print entire page)
  - **NOTE:** Click **Force Black and White** if you don't want your printout to have gray shading
3. Click **Print**

## Highlighting

### TO EXTRACT HIGHLIGHTED TEXT & SAVE AS SEPARATE DOCUMENT:

1. **File** menu > **Extract Annotations**
2. In **Extract** dialog box, click **Highlights**
3. Under **Highlights**, click to uncheck any highlight color you did not use  
(*Example: Magenta*)
4. Click **OK**
5. Result:
  - Creates a new document that contains highlighted text
  - Text is shown with original highlight colors

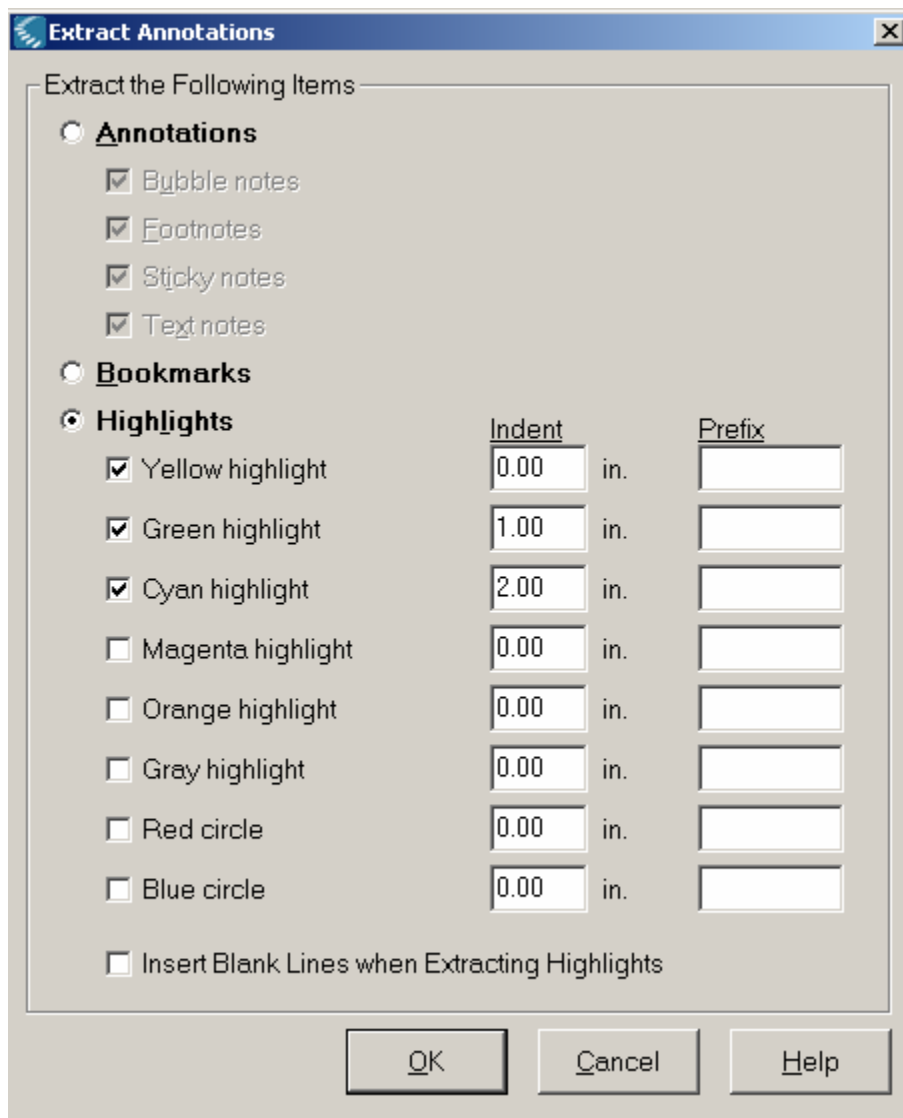

## Highlighting

### TO SAVE EXTRACTED TEXT AS SEPARATE DOCUMENT:

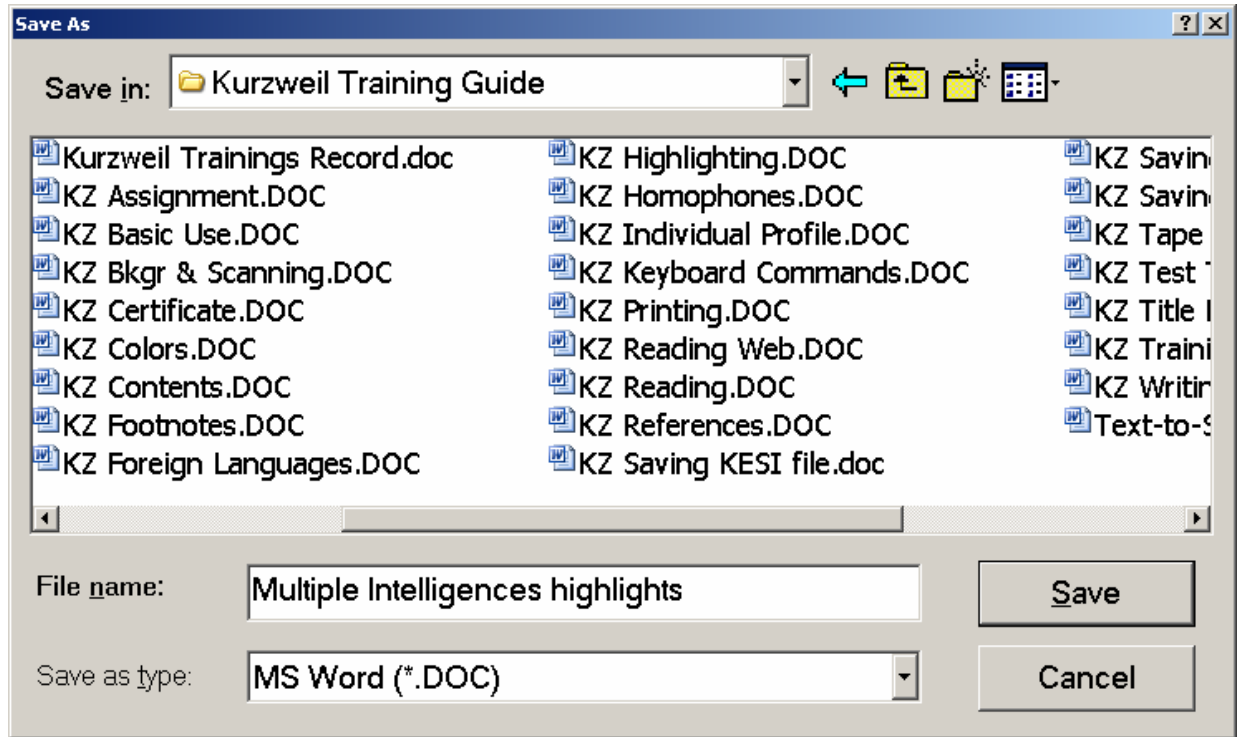

1. Insert your flash drive or floppy disk
2. Click **Save** on toolbar <OR> *Keyboard: <Ctrl> + S*
3. In Save As dialog box:
  - Click **Save in** box & click **Removable Disk** or **3½ Floppy (A:)**
  - Double-click **File name** box & type your file name (no extension)
  - Click **Save as type** box & click **MS Word**
  - Click **Save**

DSP&S  
Butte College

## Study Skills: Footnotes Kurzweil 3000

### BACKGROUND:

- Lets you attach footnotes to specific items in document
- Easier to use with Study Skills toolbar
- Enable Editing (in Edit menu) must be checked

**TO DISPLAY STUDY SKILLS TOOLBAR:** (Click **green bar** on toolbar)



### TO ADD NOTE:

1. Click to position caret where you want note attached
2. Click **Footnote** on Study Skills toolbar, <OR>  
*Keyboard: <Shift> + F5*
3. Result:
  - Puts a Note anchor (number) at caret position
  - Displays area for you to write notes
4. To have note read aloud as you type:
  - **Tools** menu > **Options** <OR> *Keyboard: <Ctrl> + F1*
  - Click **General**

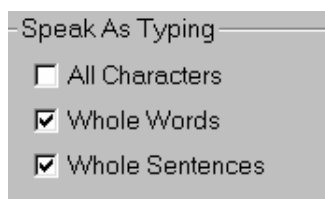

- In **Speak As Typing** section, place checkmark next to what you want:
  - Characters, Words, Sentences
  - You can choose more than one (or none)
- Click **OK**

### TO CLOSE NOTE:



1. Click **Close** on Study Skills toolbar, <OR>

*Keyboard:* <**Shift**> + **F6**

### TO VIEW AND READ NOTES:

1. Double-click the **Note anchor** (number) attached to a footnote
2. Associated footnote will appear and will be read aloud
3. When finished, click **Close** on Study Skills toolbar

### TO PRINT NOTES:

1. Click **Print**
2. Under **Print Options**, click **Notes**
3. Click **Print**

### TO DELETE NOTES:



1. Click the **Note anchor** (number) attached to note you want to delete. This will turn the number red.
2. Click **Delete** on Study Skills toolbar
3. Do you want to permanently delete the selected footnote? Click **Yes**

**Printing  
Kurzweil 3000**

**STANDARD PRINTING:**

1. Click **Print** on toolbar <OR> *Keyboard: <Ctrl> + P*
2. Under Print Options, select one of the following:
  - **Document**
  - **Notes**
  - **Highlighted Text**
3. Click **Print**

**PRINTING IN LARGE PRINT:**

**NOTE: All images will be lost when printing in large print**

1. Save as MS Word or Rich Text Format document:
  - **File** menu > **Save As**
  - In Save As dialog box, type your new file name
  - In Save as type box, click **MS Word** or **Rich Text Format**
  - Click **Save**, then click **Yes** to “All images will be lost”
2. Display the Writing Toolbar:
  - Click blue bar on toolbar
3. Change font size:
  - Press <Ctrl> + **A** to select entire document
  - Use writing toolbar to choose the font face and size you want
4. Print:
  - Click **Print** on toolbar, select **Document**, then click **Print**

DSP&S  
Butte College

## Writing: Basics & Spell Check Kurzweil 3000

- Reads your writing aloud as you type

### TO DISPLAY WRITING TOOLBAR:

To use the writing option, you need the writing toolbar:



1. Click **blue bar** on left side of toolbar

<OR>

1. Right-click any toolbar
2. Click **Writing** in menu

### TO CHOOSE WHAT IS READ ALOUD AS YOU TYPE:

1. **Tools menu > Options** <OR> *Keyboard: <Ctrl> + F1*
2. Click **General** in Side Menu
3. In **Speak As Typing** section, checkmark what you want spoken as you type:  
All characters / Whole words / Whole sentences
4. Click **OK**

⇒ *Preferred setting: All characters / Whole words / Whole sentences / None  
(Circle one or more)*

### TO START A DOCUMENT:

1. Click **New** on toolbar
2. On Writing toolbar, adjust font:
  - *Generally, instructors prefer Times New Roman, size 12*
  - Font face: \_\_\_\_\_
  - Font size: \_\_\_\_\_ pt.

### TO READ A DOCUMENT:

Use the Kurzweil reading options to read your document

## SPELL CHECK:

NOTE: Kurzweil begins spell check at caret position and checks entire document

1. Click **Spell Check** on Writing toolbar 
2. Spell check dialog box:

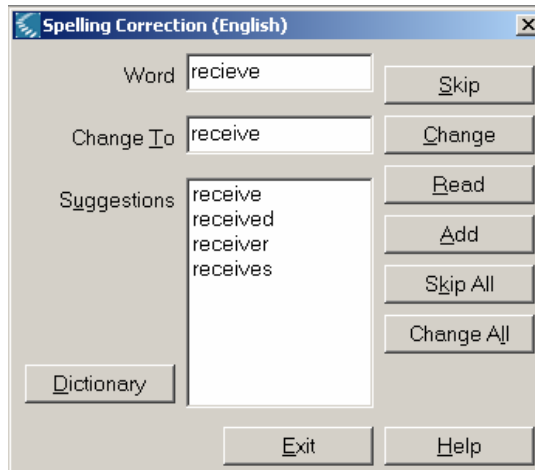

- Word: Displays the word in question
  - Change To: Suggests replacement word
  - Suggestions: Click a suggested word to hear it read aloud
3. Options:
    - Skip: Keep word as it is & continue Spell Check
    - Change: Replace with word in Change To box
    - Read: Reads words in Suggestions aloud
    - Add: Stores this word in dictionary
    - Skip All: Do not flag this word whenever it appears in this document
    - Change All: Replaces all occurrences with word in Change To box

## TO SAVE A DOCUMENT AND OPEN IT IN MS WORD:

1. Put in your flash drive (or floppy disk)
2. Click **Save** on toolbar
  - **Save In:** **Removable disk (or 3½ Floppy)**
  - **File name:** Type new file name
  - **Save as type:** **MS Word**
3. Click **Save** & close Kurzweil; use MS Word to make additional changes

DSP&S  
Butte College

## Writing: Word Prediction Kurzweil 3000

### WORD PREDICTION:

- Completes a word after you begin typing
- Reads words aloud when you click them (in Word Prediction window)
- Keeps track of your word choices and adjusts its word list accordingly

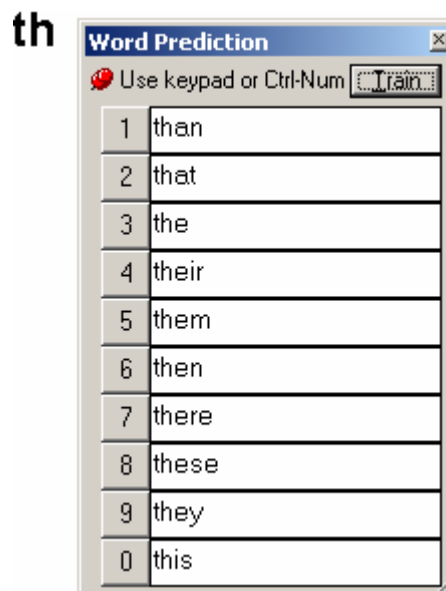

To use:

1. Click **Word Prediction** on Writing toolbar 
2. As you type, watch Word Prediction window
3. If the word you want appears:
  - Click number next to word, **<OR>**
  - Press corresponding number on Number keypad, **<OR>**
  - Press **<Ctrl> + number of that word**

⇒ *Preferred setting: Word Prediction On / Off (Circle one)*

## WORD PREDICTION: PHONETIC SPELLING

- Additional feature: Will also recognize words spelled phonetically

- *Examples*:

Spelled correctly	Spelled phonetically
school	skool
knew	new
(your word?)	

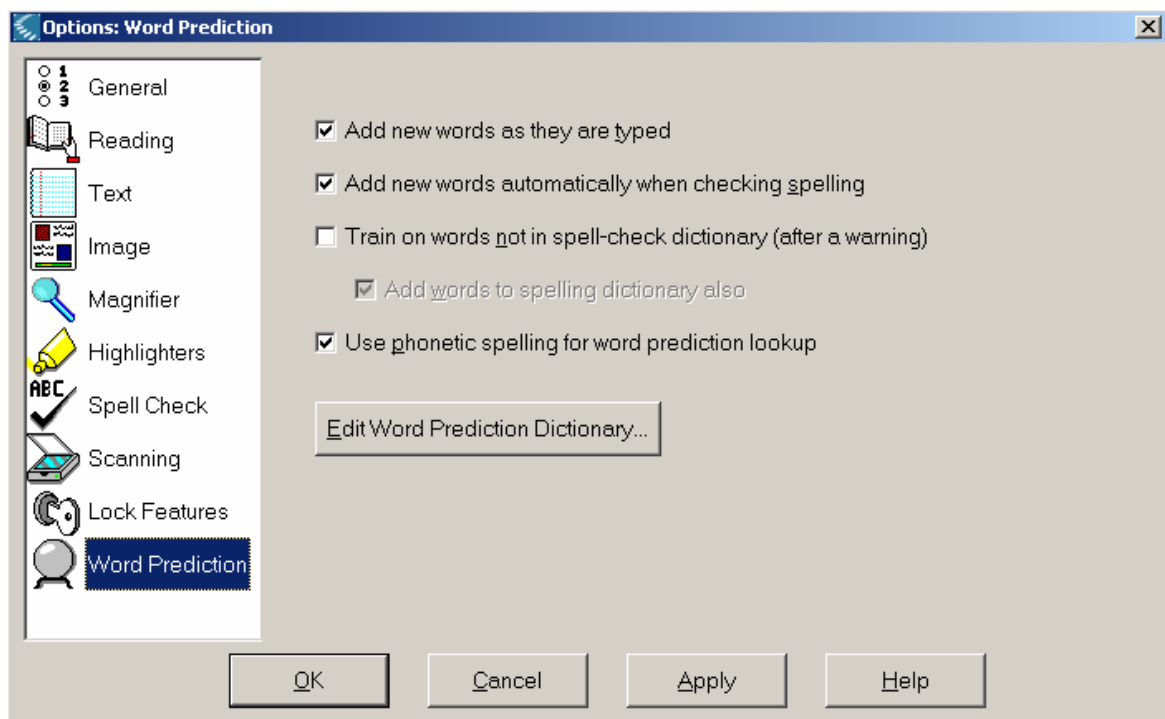

To use the phonetic spelling feature:

1. Click **Word Prediction** on Writing toolbar 
2. **Tools** menu > **Options**
3. Click **Word Prediction** in Side Menu
4. In **Options: Word Prediction** dialog box, checkmark:  
✓ **Use phonetic spelling for word prediction lookup**
5. Click **OK**

**WORD PREDICTION: PHONETIC SPELLING (Continued)**

Test this feature with words you tend to spell phonetically

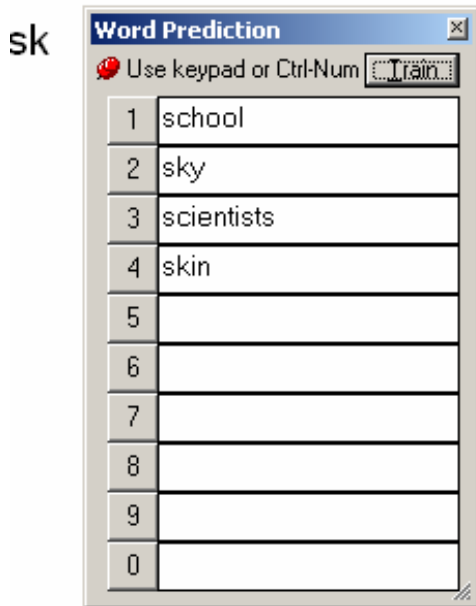

⇒ Preferred setting: *Phonetic spelling feature On / Off (Circle one)*

⇒ Words you tend to spell phonetically:

Your spelling	Correct spelling

## WORD PREDICTION: HOMOPHONES

- **Homophones:** Words that sound the same, but are spelled differently
  - *Example:* there / their / they're
- Highlights homophones in Word Prediction window

### TO USE:

1. **Tools** menu > **Vocabulary Lists**
2. Click to checkmark the Homophone list you want to include

### NOTE: Each list also includes words from the lower-level list

- Homophone I: Words misused at Elementary grade level  
*Example:* bear / bare
  - Homophone II: Words misused at Middle School level  
*Example:* allowed / aloud
  - Homophone III: Words misused at High School level  
*Example:* assent / ascent
3. Click **Options**
  4. Click to checkmark:
    - ✓ Highlight these words in word prediction window
  5. Click a Highlight Color
  6. Click **OK**, then click **OK** again

- **Click homophone** to have it read aloud & hear definition
- **Double-click homophone** to see comparison:

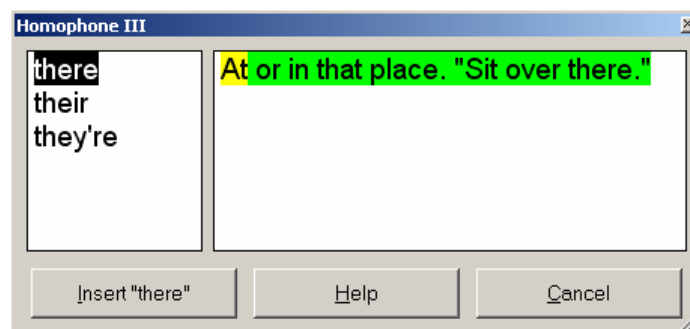

⇒ *Preferred setting:*

*Off / Homophone I / Homophone II / Homophone III (Circle one)*

## WORD PREDICTION: CONFUSABLES

- Highlights commonly-confused words in Word Prediction window
  - *Example:* lose / loose

### TO USE:

1. **Tools** menu > **Vocabulary Lists**
2. Click to checkmark the Confusables list you want

### **NOTE: Each list also includes words from the lower-level list**

- Confusable I: Words confused at Elementary grade level  
*Example:* does / dose
  - Confusable II: Words confused at Middle School level  
*Example:* conservation / conversation
  - Confusable III: Words confused at High School level  
*Example:* vicious / viscous
3. Click **Options**
  4. Click to checkmark:
    - ✓ Highlight these words in word prediction window
  5. Click a Highlight Color
  6. Click **OK**, then click **OK** again
- **Click confusable** to have it read aloud & hear word it is confused with
    - *Example:* Says “loose” confusable with “lose”
  - **Double-click confusable** to see comparison:

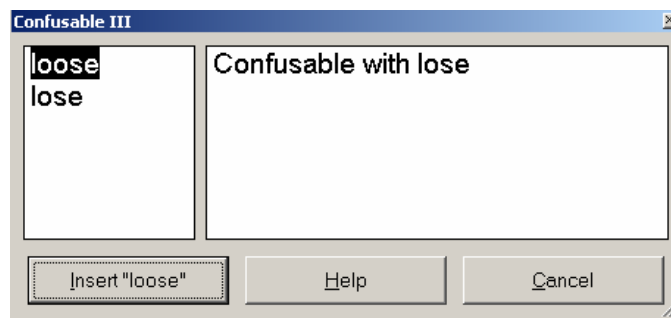

⇒ *Preferred setting:*

*Off / Confusable I / Confusable II / Confusable III (Circle one)*

DSP&S  
Butte College

## Fill in the Blanks Kurzweil 3000

### BACKGROUND:

- Lets you scan pages in workbook & hear your answers read aloud
- Listen to your work:
  - ✓ Read instructions aloud
  - ✓ Read an item and complete it
  - ✓ Read completed item
- Use with Writing toolbar

### TO DISPLAY WRITING TOOLBAR:

1. Click **blue bar** on left end of toolbar

### TO SET UP:

1. Scan text and the related fill-in-the-blank workbook pages
2. **Tools** menu > **Fill in the Blanks**
3. Result:
  - Puts orange markers at beginning of each blank to be filled in

### TO FILL IN THE BLANKS:

1. Click **Read** to hear a workbook item
2. Click the orange marker to make it hollow, and type your answer
3. Click **Read** again to check your answer by having the completed item read aloud

### TO PRINT ASSIGNMENT:

1. Click **Print** on toolbar
2. Click **Document** (if needed)
3. Click **Current Page** (if needed)
4. Click **Print**

**PRACTICE: FILL IN THE BLANKS & WRITING**

PE 120

Quiz 1

- ✓ Part I: Please fill in the blanks, choosing your answers from the following list:

agility	circuit
atrophy	dumbbells
barbells	endurance

1. The ability to persist in physical activity is called \_\_\_\_\_.
2. A prescribed program by which an individual moves from station to station is called a \_\_\_\_\_.
3. Steel bars usually six to seven feet in length with removable metal collars are called \_\_\_\_\_.
4. A decrease of muscle tone is described as \_\_\_\_\_.
5. A scaled-down version of barbells is called \_\_\_\_\_.
6. The capacity to change direction and position rapidly is called \_\_\_\_\_.

- ✓ Part II: Short-answer essay: Please write the procedure for setting up an exercise program for a client with asthma.

DSP&S  
Butte College

## Internet: Reading the Web Kurzweil 3000

**NOTE:** Depending on how they are created, some web pages cannot be read by the Kurzweil 3000.

### TO READ THE WEB:

1. **Read** menu > **Read the Web**

Result:

- Launches Mozilla Firefox, and
- Puts Kurzweil toolbar near top of screen

**NOTE:** You may need to click **Reload** button as needed.

### FOR BLACKBOARD USERS (if necessary):

1. **Tools** menu > **Options**
2. Click **Reading** in Side Menu
3. Under **Read the Web** (lower right):
  - Click **Mozilla Firefox**, then click **OK**

### OPTIONS:

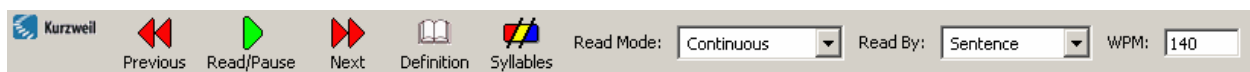

- Read/Pause
- Definition
- Syllables

Preferred settings:

- Read Mode
- Read By
- WPM

### **DEFINITION:**

1. Click the word you want (to put caret on it)
2. Click **Definition** on Kurzweil toolbar
3. Click **Read** on toolbar
4. Click **Close button (X)** when finished

### **SYLLABLES:**

1. Click the word you want (to put caret on it)
2. Click **Syllables** on Kurzweil toolbar
3. Kurzweil will say the word, breaking it down into syllables

## Saving Options

DSP&S  
Butte College

### Saving Options Kurzweil 3000

You have 3 main options for saving a scanned file:

Option	Visual output?	Graphic images?	Auditory output?	Media?	How to access it?
Microsoft Word	Yes	No	No/Yes	Flash drive or floppy disk	Microsoft Word (or Kurzweil for auditory output)
Kurzweil (KESI file)	Yes	Yes	Yes	Flash drive or CD	Kurzweil (Professional or LearnStation)
MP3	No	No	Yes	Flash drive or CD	MP3 player

#### ➔ SAVING AS AN MS WORD FILE (FLASH DRIVE OR FLOPPY DISK)

- File can be opened in MS Word
- Text cannot include notes; delete any notes
- See directions, page 25

#### ➔ SAVING AS A KURZWEIL FILE (FLASH DRIVE OR CD)

- Graphic images will be saved – will retain same appearance
- KESI file can be read by either Kurzweil program:
  - **Kurzweil Professional: Scan & read**
  - **Kurzweil LearnStation: Read only**
- See directions, page 36

#### ➔ SAVING AS AN MP3 FILE (FLASH DRIVE OR CD)

- Results in an audio file – for listening only
- MP3 file can be listened to on an MP3 player or most computers
- See directions, page 44

DSP&S  
Butte College

### Saving: Kurzweil File Kurzweil 3000

For this option, you need a **flash drive or CD (CD-R or CD-RW)**.

NOTE: If you use a CD-R, be careful not to close the session.

This will allow you to:

- Save your file as a Kurzweil file (KESI, or .kes)
- Save additional files or delete files at a later time
- Read the files at any time using the Kurzweil 3000 (Professional or LearnStation)

**This process involves:**

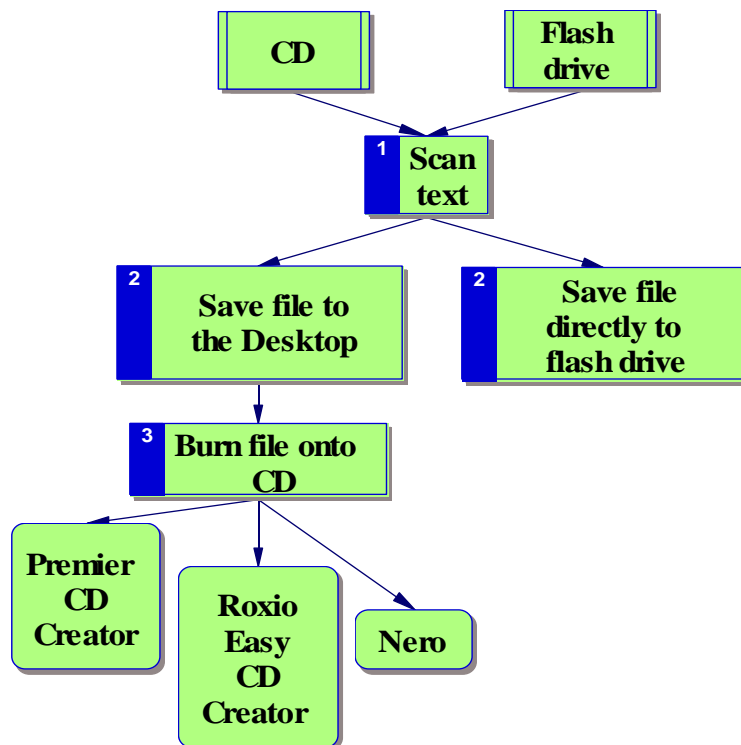

### SAVING TO CD:

(1) Scan text

(2) Save file to Desktop:

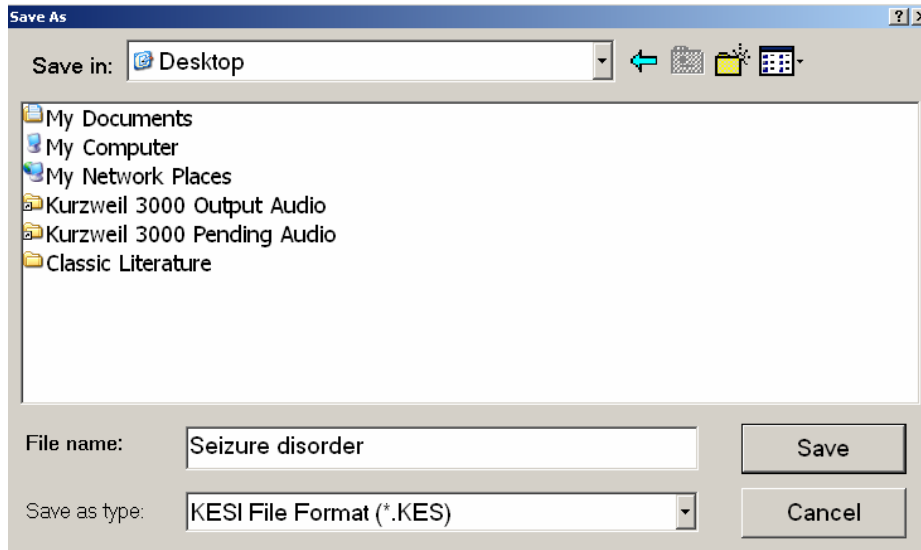

1. Click **Save** on toolbar
2. In **Save As** dialog box:
  - Save in: **Desktop**
  - File name: (Your choice – be specific)
  - Save as type: **KESI File Format (\*.KES)**
  - Click **Save:** This will save the file as a Kurzweil (.kes) file
3. Close Kurzweil

## Saving: Kurzweil File

### (3a) Burn the file onto a CD

#### ➤ Using Premier CD Creator:

1. Insert CD
2. Launch **Premier CD Creator:**
  - **Start > Programs > Assistive Technology > Premier Burning Software**
  - In Premier window, click **Make a Data CD**

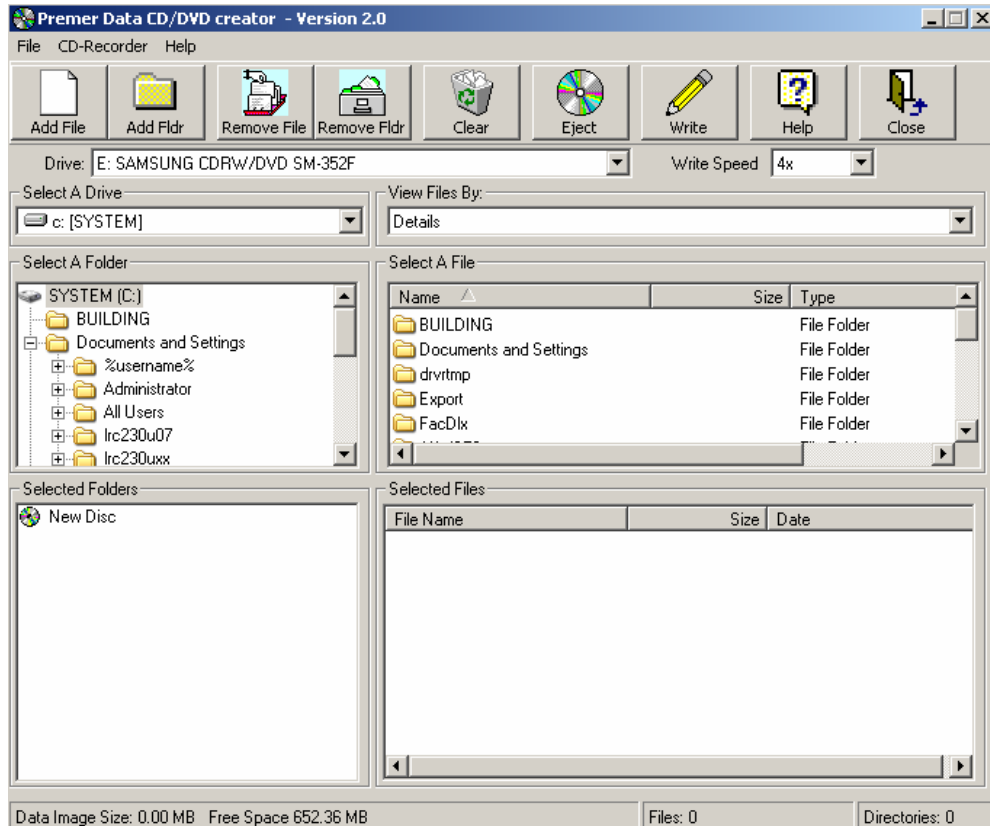

#### 3. Select File:

- **CD-Recorder** menu > **Import Previous Session**
- Select a Drive: **C: [SYSTEM]**
- Select a Folder: Click + next to **Documents & Settings** folder
  - Click + next to lrc230 u(and a number)
  - Click **Desktop**
- Select a File:
  - In right frame, click the file you want
  - Click **Add File** – this places file in Selected Files frame

## **Saving: Kurzweil File**

4. Click **Write**

Write to Disk dialog box:

- Select text box next to Volume Name & delete current words
- Type your last name
- Click **Write Disc** – wait while it writes to CD & closes session

5. **“Writing is complete!”**

- When you see this message, click **OK**
- CD will pop out
- Click **Done**
- Close Premier Data CD dialog boxes

6. **Check file on CD, then delete it from Desktop (see p. 41)**

## Saving: Kurzweil File

### (3b) Burn the file onto a CD

#### ➤ Using Roxio Easy CD Creator:

1. Insert CD
2. Double-click **Roxio Burning Software** on the Desktop
3. Select a Project:
  - Highlight: **make a data CD**
  - Click: **data CD project**

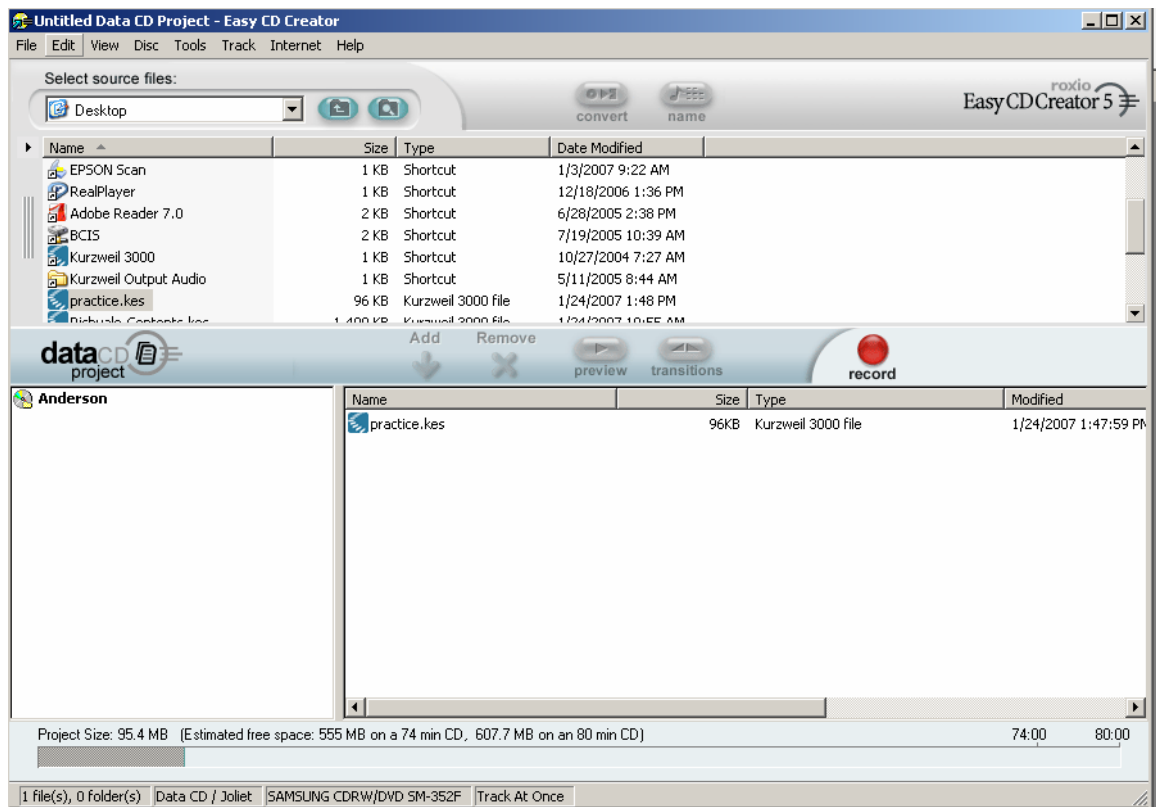

4. Data CD Project dialog box:
  - Click to select the file you want
  - Click **Add**
  - Click to select **New Disc** in left frame; type your last name & press **Enter**
  - Click **record (red button)**
5. Next dialog box: Click **Start Recording**
6. Click **OK** when both progress bars display 100%
7. Close Easy CD Creator windows
8. **Check file on CD, then delete it from Desktop (see p. 41)**

### (3c) Burn the file onto a CD

#### ➤ Using Nero:

1. Insert CD
2. Launch **Nero**: Double-click **Nero** icon on the Desktop
  - Highlight **Data** icon
  - Click **Make Data Disc**
  - Nero Express window will be displayed – this takes awhile
3. Click **Add** button on right
4. Select Files & Folders:
  - Click the file you want to select it
  - Click **Add**
  - Click **Finished**
5. Click **Next**
6. Select name in **Disc name** field & type your name
7. Click **Burn**
  - Click **OK**: “Burn process completed successfully”
8. Click **Next** - CD will pop out, then click **Exit**
9. Click **No**: “Do you want to save your project?”
10. In Nero window, click **Exit**
11. **Check file on CD, then delete it from Desktop (see below)**

### Check file on CD, then delete it from Desktop:

#### ✓ **Kurzweil 3000: (either Professional or LearnStation)**

1. Launch Kurzweil 3000 & click **Open** on toolbar
2. Look in: Select appropriate drive
3. Click file to select it
4. Click **Open** and read as you normally would

#### ✓ **Delete file from Desktop:**

1. Right-click icon for your KESI file, then click **Delete**
2. Confirm File Delete: Click **Yes**, then Empty the Recycle Bin

### SAVING TO FLASH DRIVE:

- (1) Scan text
- (2) Save file directly to flash drive:

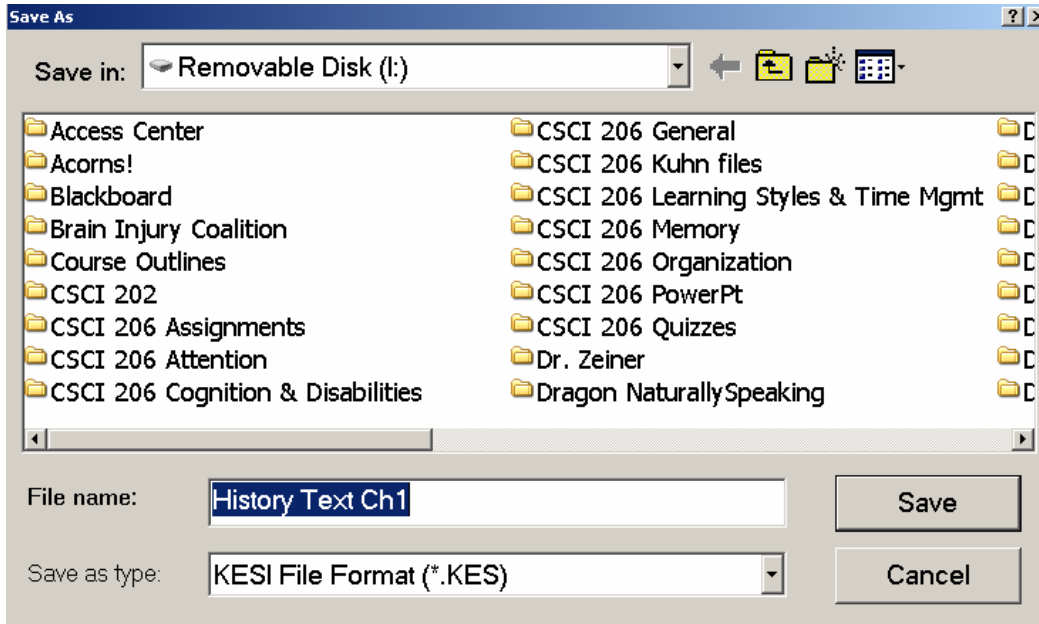

1. Click **Save** on toolbar
2. In **Save As** dialog box:
  - Save in: **Removable Disk (or brand name on flash drive)**
  - File name: (Your choice – be specific)
  - Save as type: **KESI File Format (\*.KES)**
  - Click **Save:** This will save the file as a Kurzweil (.kes) file
3. Close Kurzweil

### Check file on flash drive:

#### ✓ **Kurzweil 3000: (either Professional or LearnStation computer)**

1. Launch Kurzweil 3000
2. Click **Open** on toolbar
3. Look in: Select appropriate drive
4. Click file to select it
5. Click **Open** and read as you normally would

## Saving: Kurzweil File

### READING KURZWEIL FILES CREATED BY ALTERNATE MEDIA SERVICES:

- This service may be provided through DSPS if you qualify for Alternate Media
- For this option, you need to have Kurzweil files saved on a CD (or flash drive).
- You can read these files with either Kurzweil program:
  - **Kurzweil Professional (Scan & Read)**
  - **Kurzweil LearnStation (Read Only)**

### Kurzweil Files (.kes):

1. Insert CD (or flash drive)
2. Launch Kurzweil 3000
3. Adjust settings according to your individual preferences
4. Click **Open** on toolbar
5. Look in: (choose appropriate drive)

**NOTE:** If you have Alternate Media services, the material is usually divided into folders:

- Front Matter
    - *Examples:* Table of Contents, Preface, Introduction
  - Chapters
    - *Examples:* 01 Chapter.kes, 02 Chapter.kes, etc.
  - Back Matter
    - *Examples:* Index, Glossary
  - MP3 (optional)
6. Click the folder you want (Front, Chapters, or Back) & click **Open**
  7. Click the file you want & click **Open**
  8. Use Kurzweil as you normally do to read the file
  9. **NOTE:** If you want to use additional options—for example, highlighting—save the file to Drive C.

## Saving: MP3 File

DSP&S  
Butte College

### Saving: MP3 File Kurzweil 3000

For this option, you need a **flash drive or CD (CD-R or CD-RW)**.

NOTE: If you use a CD-R, be careful not to close the session.

This will allow you to:

- Save your file as an MP3 file (.mp3)
- Listen to the files using an MP3 player or software on your computer
  - *Example:* Windows Media Player

This process involves:

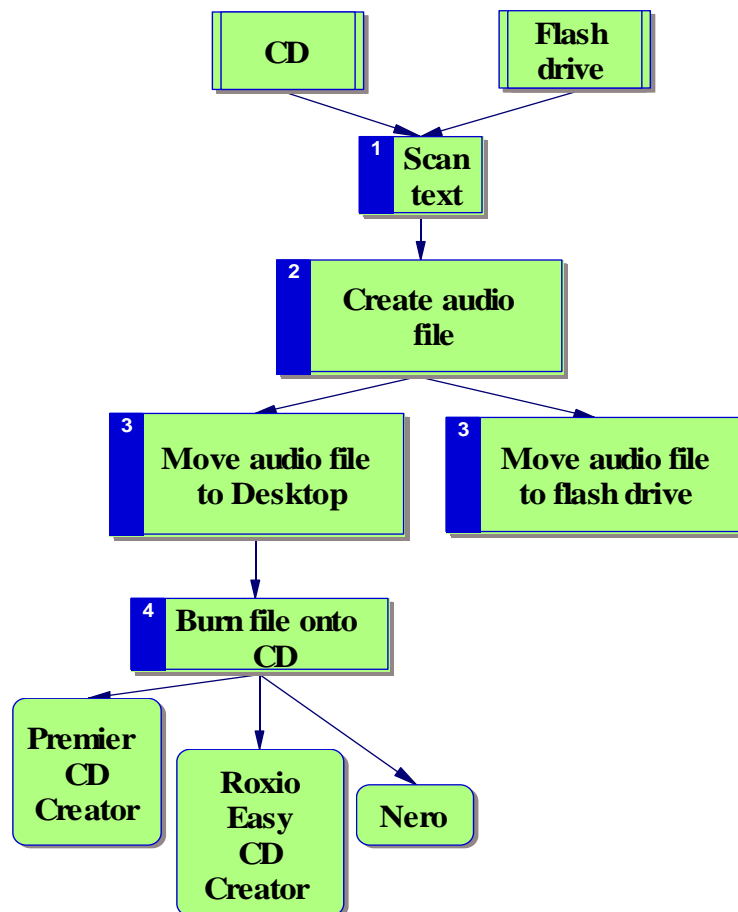

## Saving: MP3 File

### SAVING TO CD:

- (1) Scan text
- (2) Create audio file:

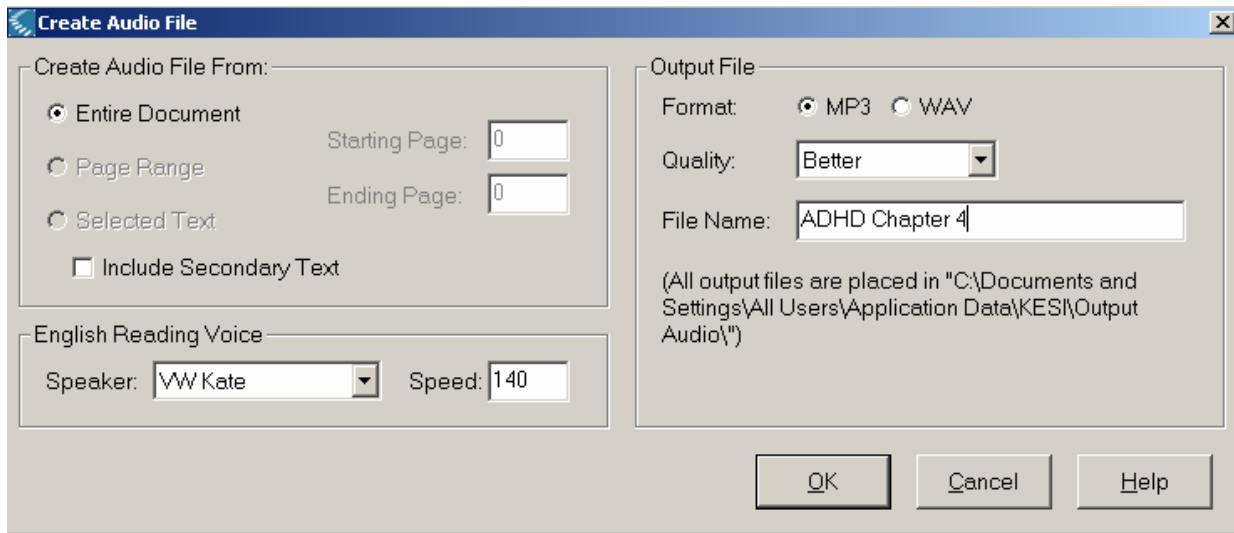

1. **File menu > Audio Files > Create Audio File**
2. In **Create Audio File** dialog box:
  - Create Audio File From - Select:
    - Entire Document
    - Page Range (then specify Starting & Ending Page #)
    - Selected Text
  - Reading Voice:
    - Select your preferred reading voice & speed
  - Output File:
    - Format: Select MP3 (*Default*)
    - **Quality: Good / Better / Best (start with Better)**
    - File name:
      - Name the file – be specific
      - Add **.mp3** extension (if necessary)
  - Click **OK**: All output files will be placed on Drive C (in Kurzweil Output Audio folder)
    - Close Kurzweil

## Saving: MP3 File

### (3) Move audio file to Desktop:

1. Wait a few minutes for audio file to be created
2. On the Desktop, double-click folder **Kurzweil Output Audio**
3. Click & drag your file onto the Desktop
4. Close Output Audio window

### (4a) Burn File to CD

#### ➤ Using Premier CD Creator:

1. Insert CD
2. Launch **Premier CD Creator:**
  - **Start > Programs > Assistive Technology > Premier Burning Software**
  - In Premier window, click **Make a Data CD**

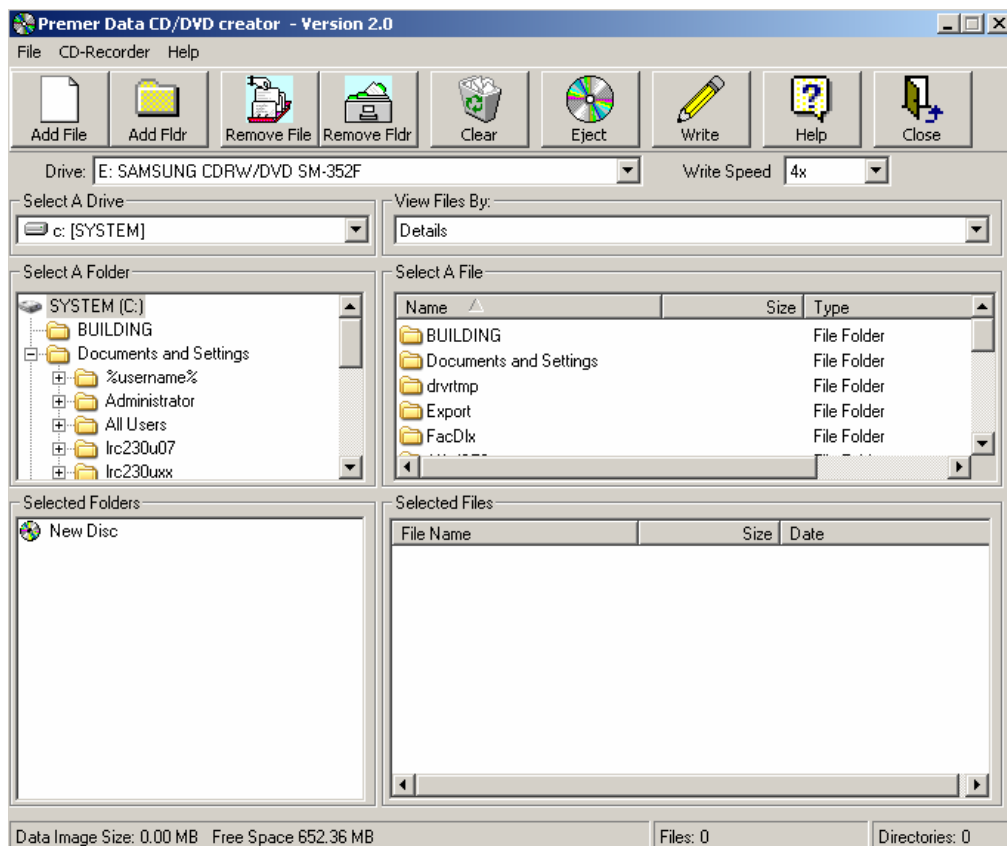

## Saving: MP3 File

3. Select File:
  - **CD-Recorder** menu > **Import Previous Session**
  - Select a Drive:
    - **C: [SYSTEM]**
  - Select a Folder:
    - Click + next to **Documents & Settings** folder
    - Click + next to lrc230 u(and a number)
    - Click **Desktop**
  - Select a File:
    - In right frame, click the file you want
    - Click **Add File** – this places file in Selected Files frame
  
4. Click **Write**  
Write to Disk dialog box:
  - Select text box next to Volume Name & delete current words
  - Type your last name
  - Click **Write Disc** – wait while it writes to CD & closes session
  
5. “Writing is complete!”
  - When you see this message, click **OK**
  - CD will pop out - Click **Done**
  - Close Premier Data CD dialog boxes
  
6. **Check file on CD, then delete it from Desktop (see p. 49)**

## Saving: MP3 File

### (4b) Burn File to CD

#### ➤ Using Roxio Easy CD Creator:

1. Insert CD
2. Double-click **Roxio Burning Software** on the Desktop
3. Select a Project:
  - Highlight: **make a data CD**
  - Click: **data CD project**

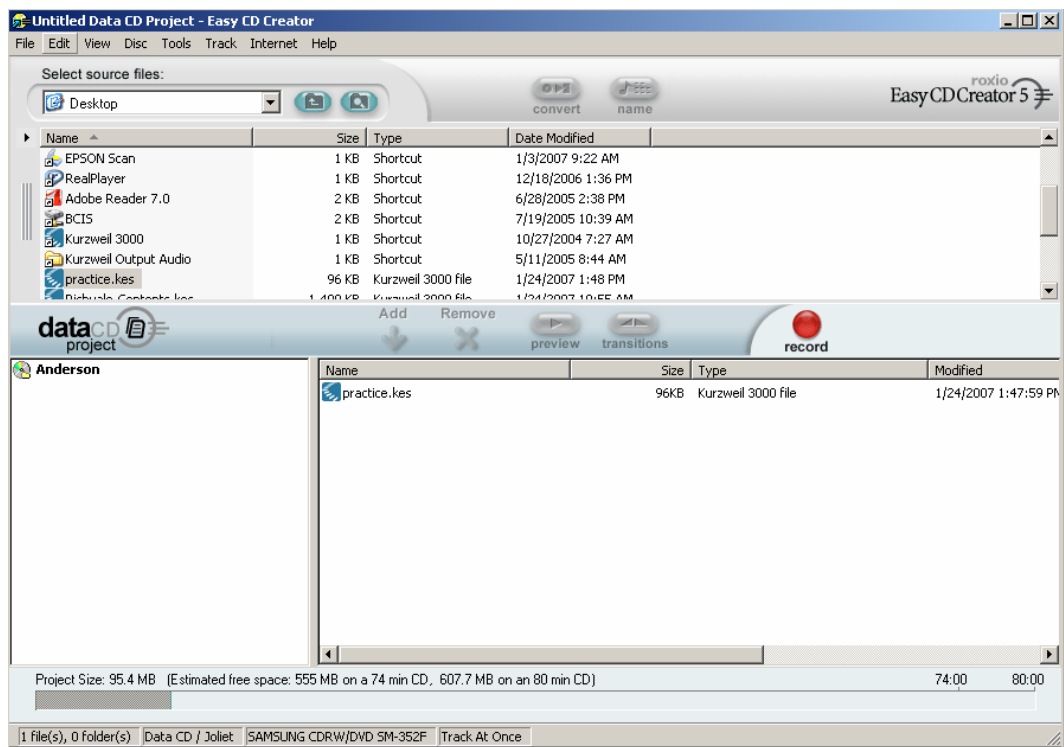

4. Data CD Project dialog box:
  - Click to select the file you want
  - Click **Add**
  - Click to in left frame to rename disc; type your last name & press **Enter**
  - Click **record (red button)**
5. Next dialog box: Click **Start Recording**
6. Click **OK** when both progress bars display 100%
7. Close Easy CD Creator windows
8. **Check file on CD, then delete it from Desktop (see p. 49)**

### (4c) Burn File to CD

#### ➤ Using Nero:

1. Put CD in recordable CD drive
2. Launch **Nero**: Double-click **Nero** icon on the Desktop
  - Highlight **Data** icon & click **Make Data Disc**
  - Nero Express window will be displayed – this takes awhile
3. Click **Add** button on right
4. Select Files & Folders:
  - Click the file you want to select it
  - Click **Add**
  - Click **Finished**
5. Click **Next**
6. Select name in Disc name field & type your name
7. Click **Burn**
  - Click **OK**: “Burn process completed successfully”
8. Click **Next** - CD will pop out
9. Click **Exit**
10. Click **No**: “Do you want to save your project?”
11. In Nero window, click **Exit**
12. **Check file on CD, then delete it from Desktop (see below)**

### Check file on CD, then delete it from Desktop:

#### ✓ **My Computer**

1. Double-click **My Computer** on the Desktop
2. Double-click drive with CD
3. Double-click the MP3 file & listen

#### ✓ **Delete file from Desktop:**

1. Right-click icon for your MP3 file, then click **Delete**
2. Confirm File Delete: Click **Yes**, then Empty the Recycle Bin

**SAVING TO FLASH DRIVE:**

**(1) Scan text**

**(2) Create audio file (see directions, p. 45)**

**(3) Move audio file to flash drive:**

1. On the Desktop, double-click the folder **Kurzweil Output Audio**
2. Insert flash drive
3. Double-click **My Computer** on the Desktop
4. Double-click drive with your flash drive
  - ✓ May be identified as Removable Disk
5. Click & drag MP3 file from Kurzweil Output Audio window to the window displaying your flash drive
6. Close My Computer & Output Audio windows

**Check file on flash drive:**

✓ **Using computer with MP3 software:**

1. Insert your flash drive
2. On the Desktop, double-click **My Computer**
3. Double-click drive with your flash drive
4. Double-click the specific MP3 file to open it
5. Click buttons to play, pause, etc.

